

## Installation instruction for triangle batten roofing, Kerabit 7

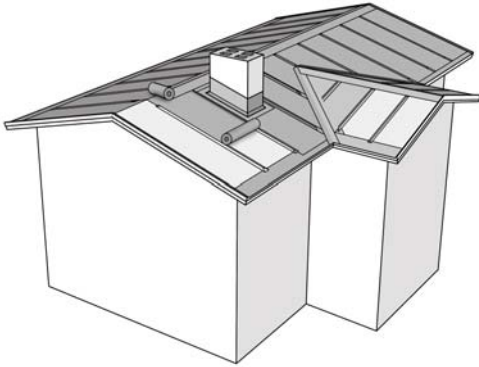

### Before installation, note the following:

Kerabit 7 triangle batten roofing is suitable for roofs with an inclination of 1:3 or steeper. Membrane rolls are to be stored in an upright position, protected from rain and sun. Before installation, keep the rolls for a period of at least 24 hours at a temperature in excess of +15 °C. Open the rolls in advance in order to allow them to straighten out. This way, folds can be prevented from developing in the finished surface. The time required by the straightening of the membrane depends on the temperature (from one to four hours). When roofing is being installed, the temperature must be higher than +10 °C and the weather must be dry (roofing must not be installed in rain).

The material can be laid onto a substrate of rough tongued and grooved boards or moisture proof tongued and grooved construction panels (e.g. Kerabit OSB roofing board). The substrate must be even, dry and must not bend.

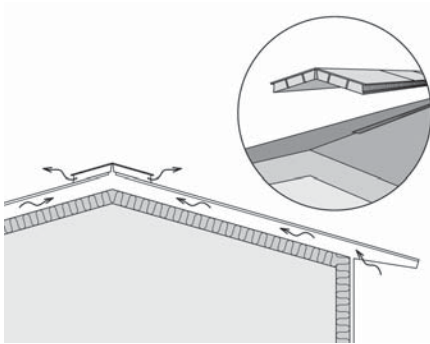

The Kerabit 7 membrane can be worked with a hooked carpet knife. For gluing, use Kerabit Sealing Adhesive. Nail the sheet using hot-galvanised clout nails. Nails must penetrate the wooden substrate, except when triangle battens are nailed. Triangle battens are attached to the substrate using wire nails.

Before starting the installation of the roofing, ensure that the substructure is properly and sufficiently ventilated. If the slope of the roof is between 1:1 and 1:3, the ventilation of the roof can be intensified using Kerabit Ridge Vent. Ridge vents must be installed to extend the entire length of the roof ridge. See a separate installation instruction for Kerabit Ridge Vent. Before installing the roofing, attach triangle battens at

the base of chimneys and upturns.

Bitumen roofing is installed from the eaves upwards in order to avoid backwater laps. Note that you should install the roofing above chimneys and major penetrations only after the penetrations are completed (see section Chimney and major penetrations). A roofing installed in accordance with the installation instructions has no visible nails. Ensure the firm fastening of seams / overlaps, for example, by walking on them. If necessary, you can facilitate the adherence of the membrane by heating its adhesive surface using a hot air blower.

### Renovation projects

In renovation projects, it is recommended that the old roofing is removed before triangle batten roofing is installed. Check that the substrates are healthy.

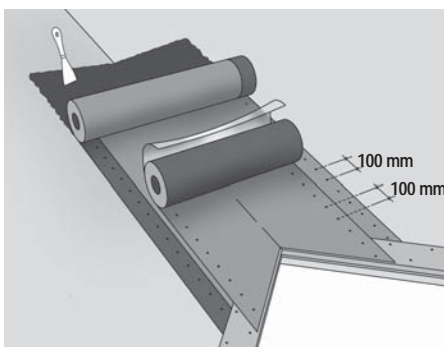

### Valleys

At the bottom of valleys, an underlayer consisting of a membrane with a polyester carrier – Kerabit 2500 UB – is installed by gluing it to the surface across the entire area (a layer of glue approx. 1 mm thick) using sealing adhesive and by nailing it to the surface at the edges with 100mm spacing. On the eaves, an eaves flashing is installed. On top of the underlay membrane, attach a Kerabit Valley Membrane the same colour as the roofing with adhesive on the bottom, and nail it at the edges at 100mm intervals.

## Sheet metal cladding of eaves

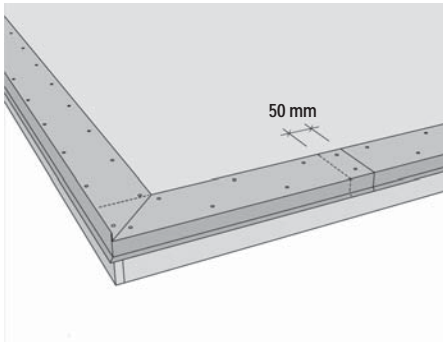

**On the eaves**, Kerabit Eave Flashing is installed. The flashing joints must overlap at least 50mm and be secured with clout nails or sheet metal screws with a KFR head in a zigzag pattern with 100mm spacing. In joints, the drip edge of the uppermost flashing is opened up in order to house the drip edge of the lower flashing.

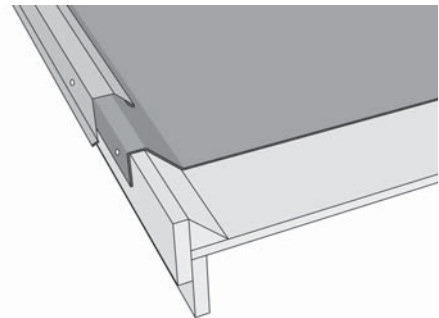
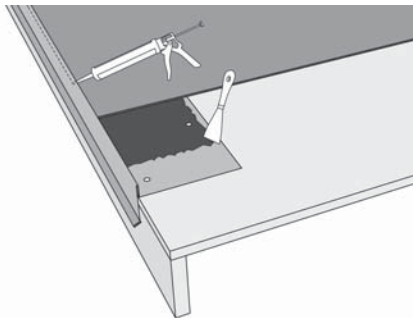
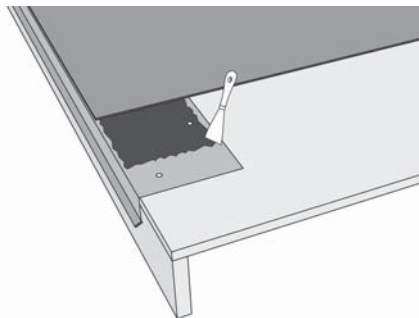
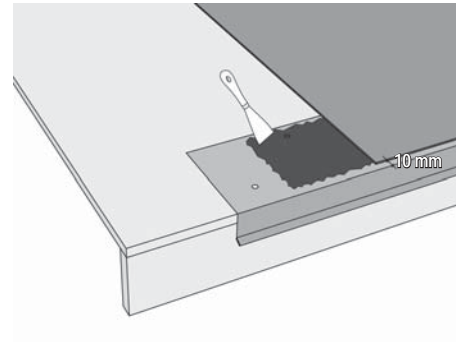

For **verges**, three alternatives exist: Kerabit Eave Flashing, Verge Flashing with ridge, and Verge Flashing. The first two must be installed before the roofing is laid, similarly to the installation of the lower eave flashing. The installation of verge flashing is started from the lower eave towards the ridge.

**Note.** When Kerabit Verge Flashing with ridge is used add Kerabit Sealing Adhesive on the seam of the membrane and the flashing. When Kerabit Verge Flashing is used, 50 x 50mm triangle battens are attached first, flanked by vergeboards. The roofing must be folded over the vergeboard and attached to it. As the final steps, verge flashing is attached to the vergeboard; see Figure above on the right.

**Top eaves** are cladded using Kerabit Verge Flashing with Ridge or Verge Flashing.

See the installation instructions for the Kerabit Verge Flashing.

## Installation of eaves membrane

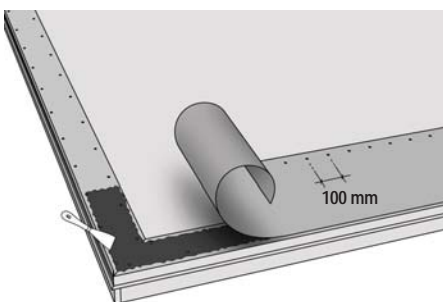

On the eaves, horizontally install Kerabit 7 membrane the width of half a roll, to form the eaves membrane. Install the lower edge of the eaves membrane approximately 10mm from the point where the eaves flashing is folded. Attach the top edge of the membrane with 100mm spacing using nails, and glue the lower edge to the eaves flashing using sealing adhesive. Taking account of the dimensions of the roof, you may also use full-width Kerabit 7 membrane, Kerabit Valley Membrane with an adhesive bottom, or Kerabit Eaves Strip.

If the roof has a valley, overlap the eaves membrane with the valley membrane by 200mm. Cut the ends of the membrane sheets to the line of the valley with the help of a measuring board, and attach them carefully using sealing adhesive along the entire overlapping section. Do not use nails!

## Attaching triangle battens

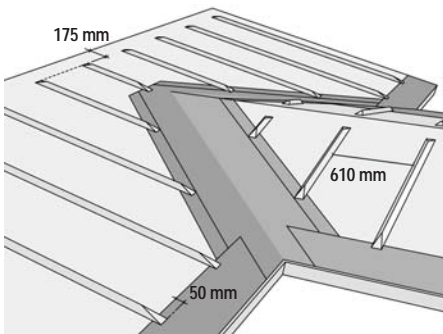

Triangle battens must be approximately 50 x 50mm in size.

Start the dimensioning of the battens from the midline of the roof plane, thereby ensuring that there will be a space of an equal width between the battens at the both ends of the roof plane. The free space between triangle battens must be 610mm, and from the midline between two battens to another midline, around 680mm.

Dimension the triangle battens so that the distance from their upper end to the ridge is around 175mm, with the lower end overlapping the eaves membrane by 50mm. Bevel both ends of the triangle battens over a distance of around 200mm. Attach the triangle battens to the substrate using nails with 300mm spacing.

At the valley, the lower ends of triangle battens must extend to the edge of the valley membrane.

## Installing Kerabit 7 membrane

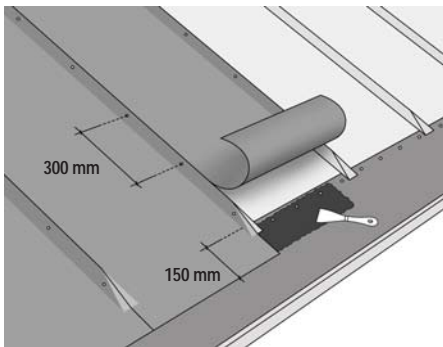

Always unroll membrane rolls in the same direction in order to avoid differences in shade. Lay Kerabit 7 between the battens so that the lower end of the membrane extends 150mm over the eaves membrane, with the upper end extending up to the ridge. Attach the upper end of the membrane using nails with 100mm spacing. Firmly press the edges of the membrane against the fold of the substrate and the triangle batten using, for example, another batten, and nail the membrane to the sides of triangle battens. Attach the lower end of the membrane on top of the eaves membrane for the entire length of the overlapping section using sealing adhesive (a layer of adhesive approx. 1 mm thick); do not use nails! In order to obtain a finished seam, use masking tape in order to protect the eaves membrane.

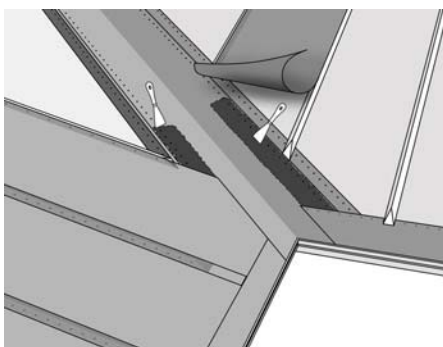

If the roof has a valley, overlap the Kerabit 7 membranes with the valley membrane by 200mm. Cut the ends of the membrane sheets to the line of the valley with the help of a measuring board, and attach them carefully using sealing adhesive along the entire overlapping section. Do not use nails!

## Extensions

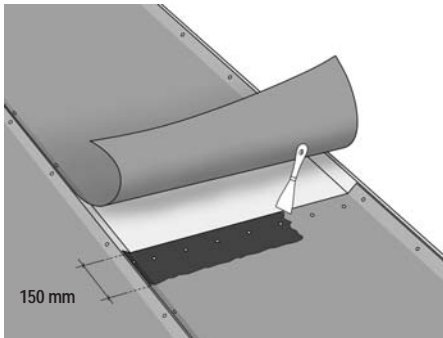

Overlap the membranes by 150mm. Attach the end of the lower membrane sheet to the substrate using nails with 100mm spacing. Attach the top membrane to the lower one across the entire overlapping section using adhesive. In order to obtain a finished seam, use masking tape.

## Installing Kerabit Triangle Batten Strip

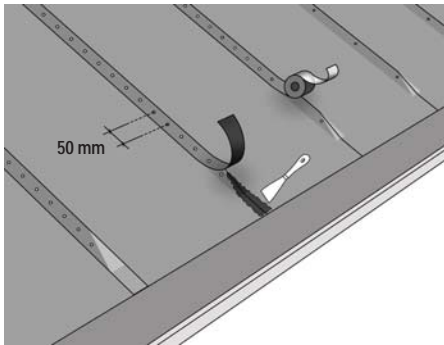

Dimension Kerabit Triangle Strips so that their upper ends extend to 0 to 70mm below the ridge, with the lower end being flush with the lower end of the Kerabit 7 membrane. Lay the strips on top of the triangle battens, remove the protective plastic film from the back of the strip, and attach the strips to both sides of the batten using nails with 50mm spacing. Attach the ends of the strips using sealing adhesive; do not use nails! For reasons of appearance, it is recommended that, where possible, Triangle Batten Strips be installed in a single length; in other words, no extensions should be used.

## Ridge

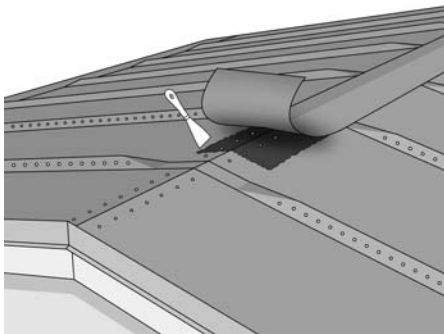

Slice the Kerabit 7 membrane so that you obtain two 350mm wide strips. Attach the strip to the ridge along its entire length using sealing adhesive. The strip laid across the ridge must not be attached with nails. Overlap the extensions by 150mm, attach the end of the lower strip to the substrate using nails with 100mm spacing, and attach the topmost strip to the lower one across the entire overlapping section using adhesive.

## Details

### Upturns

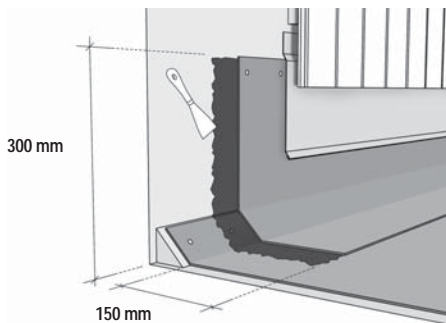

Cut the membrane strips required for the upturn so that they extend at least 300mm up the vertical surface and 150mm over the roofing at minimum. Glue the pieces throughout in place and mechanically secure the fastening of the upturn by nailing. Protect the upturn with sheet metal cladding in order to prevent water from entering between the membrane and the vertical surface.

### Round penetrations

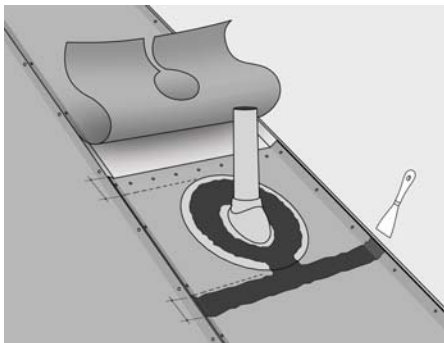

Seal round penetrations with outlet seal. Dimension the membranes so that the joint will be located at the penetration. Lay the membranes so that they overlap each other along the diameter of the collar + 300mm (see the figure). Install first the membrane that will remain under the collar. Dimension the starting point: place the sealing collar in place for a while and mark an area 150mm away from the edge of the collar. Cut a hole the size of the penetration in the membrane, and use sealing adhesive to seal the membrane to the substrate. Install the outlet seal and glue and nail the collar onto the substrate. Cut a hole the size of the lower part of the outlet seal in the membrane to be laid on top of the penetration, and lay the membrane over the collar. Glue the membrane to the collar and the membrane

beneath them using sealing adhesive. Finish off the base of the penetration using sealing adhesive.

**The chimney and major penetrations**

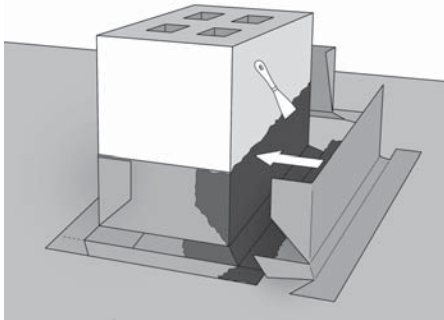

Before installing the roofing, attach a triangle batten at the base of the chimney or other major penetration in order to make the angle less steep. Below and on the sides of the penetration, install Kerabit 7 on the top edge of the triangle batten. Install the membrane above the penetration only after you have completed the upturns of the chimney.

Cut the upturned pieces from Kerabit Valley Membrane or Kerabit 7, in accordance with the adjacent figure. Glue the pieces throughout onto the chimney and substrate in the numerical order indicated in the figure. Mechanically anchor the pieces at their top edges.

Below and on the sides of the chimney, the pieces overlap the roofing; above the chimney, below it. Above the chimney, carefully glue

the roofing onto the upturned piece. Cover the section of the chimney stack above the roof with sheet metal cladding.

**Note.** Chimneys in log buildings: Construct a plywood collar around the chimney stack which is at least 400mm in height (leave a gap between the collar and the chimney) and attach it to the roof structure using a triangular batten. Continue as described above.

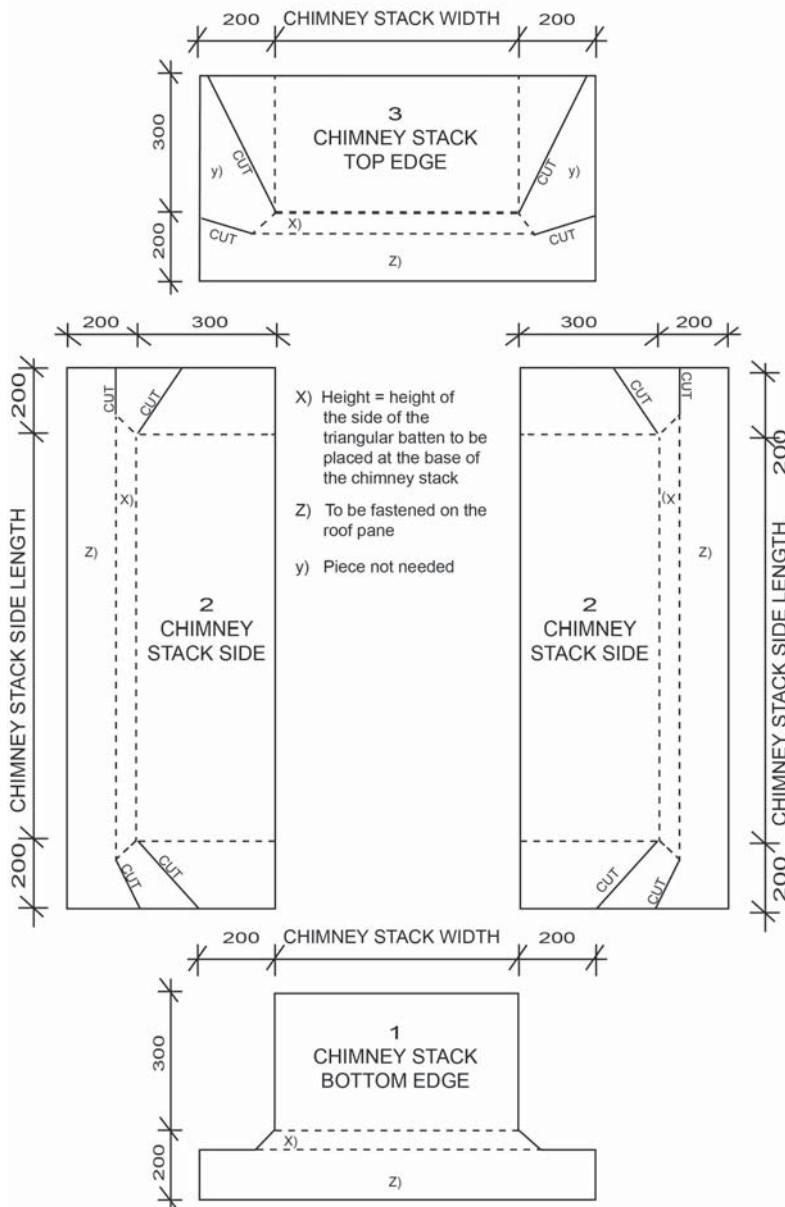

**Measures after installation**

If through fixings are installed on the roof later, ensure that they are waterproof. Check the condition of the roof at least twice every year and clean it if necessary.